

CENTER OF GRAVITY DIMENSIONS			WEIGHT DRY KG (LBS)	WEIGHT WET KG (LBS)
MODEL	CG X	CG Y		
35 REOZT4	1144 [45.0]	1027 [40.4]	1708 [3765]	1730 [3815]
45 REOZT4	1132 [44.5]	1027 [40.4]	1789 [3945]	1812 [3995]

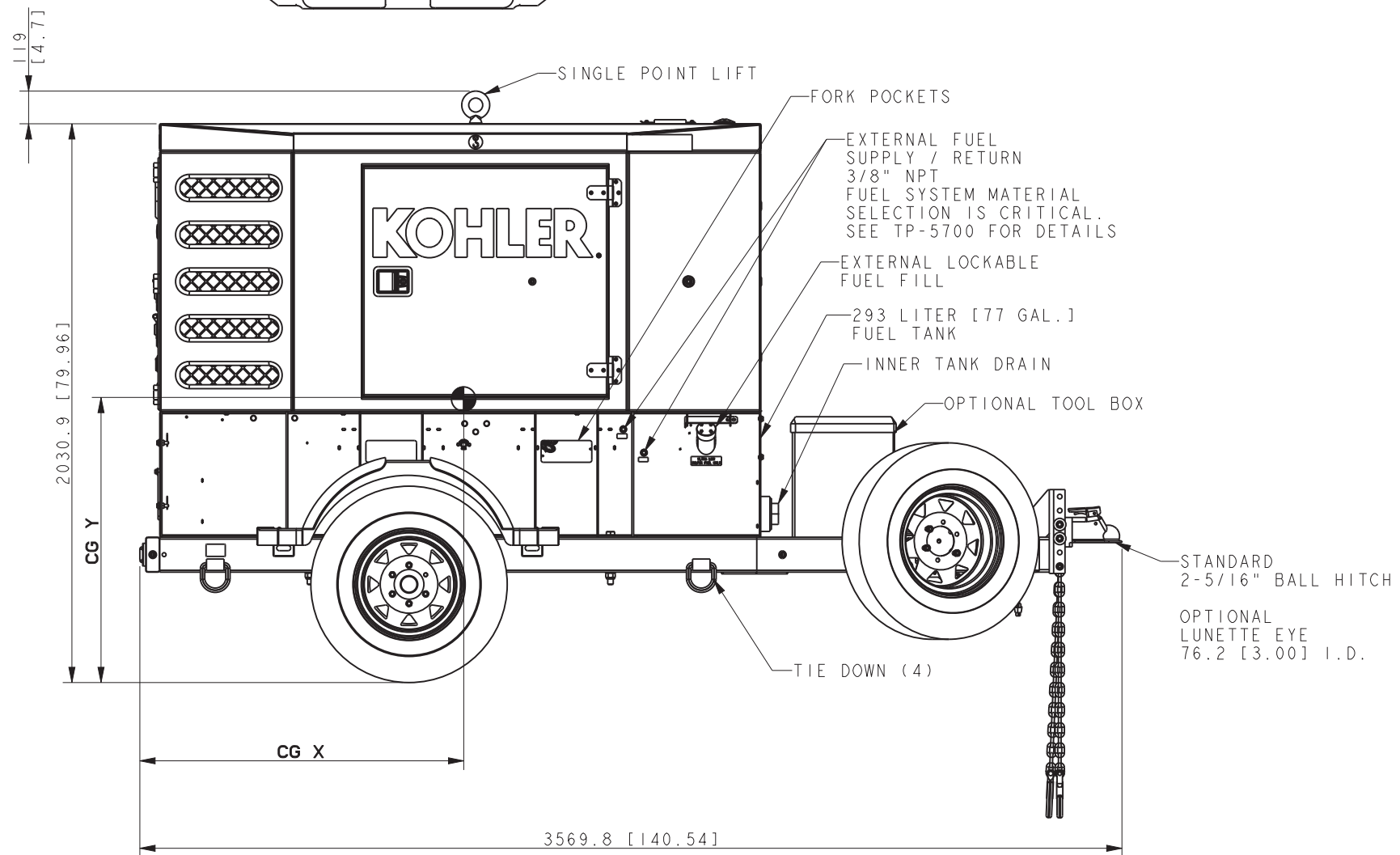
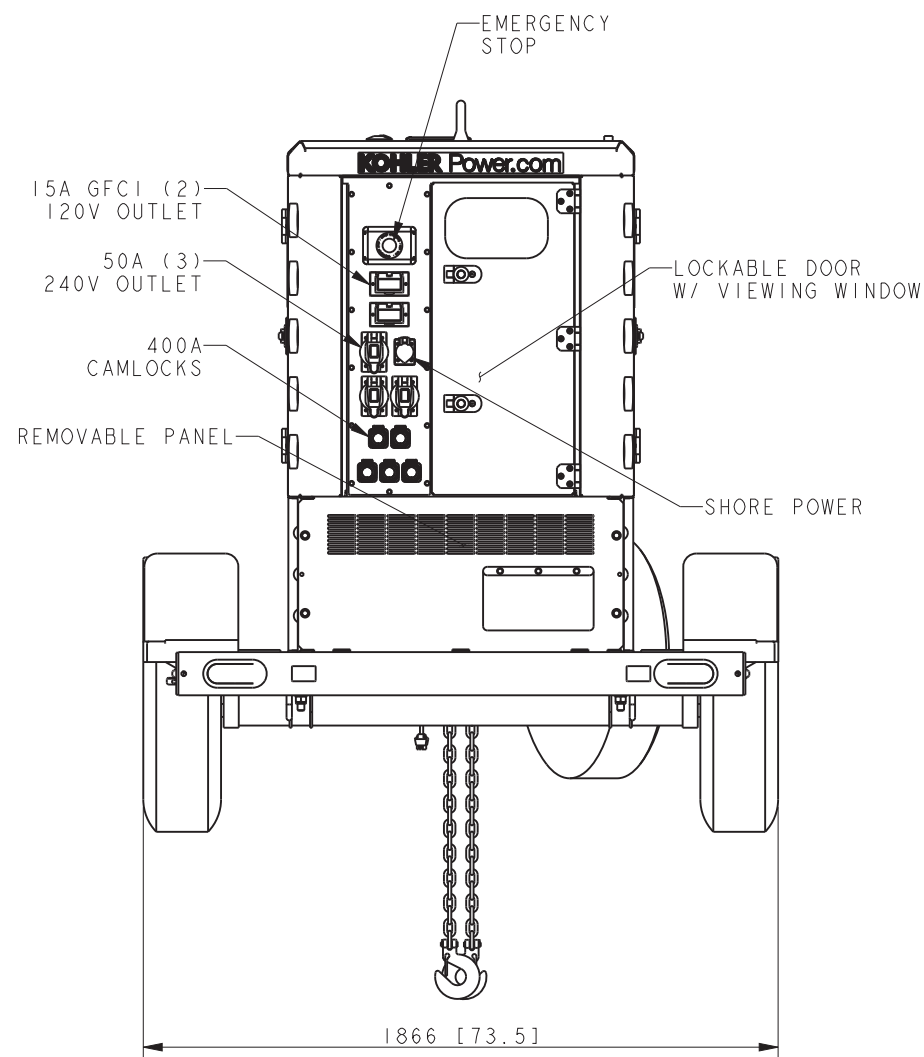
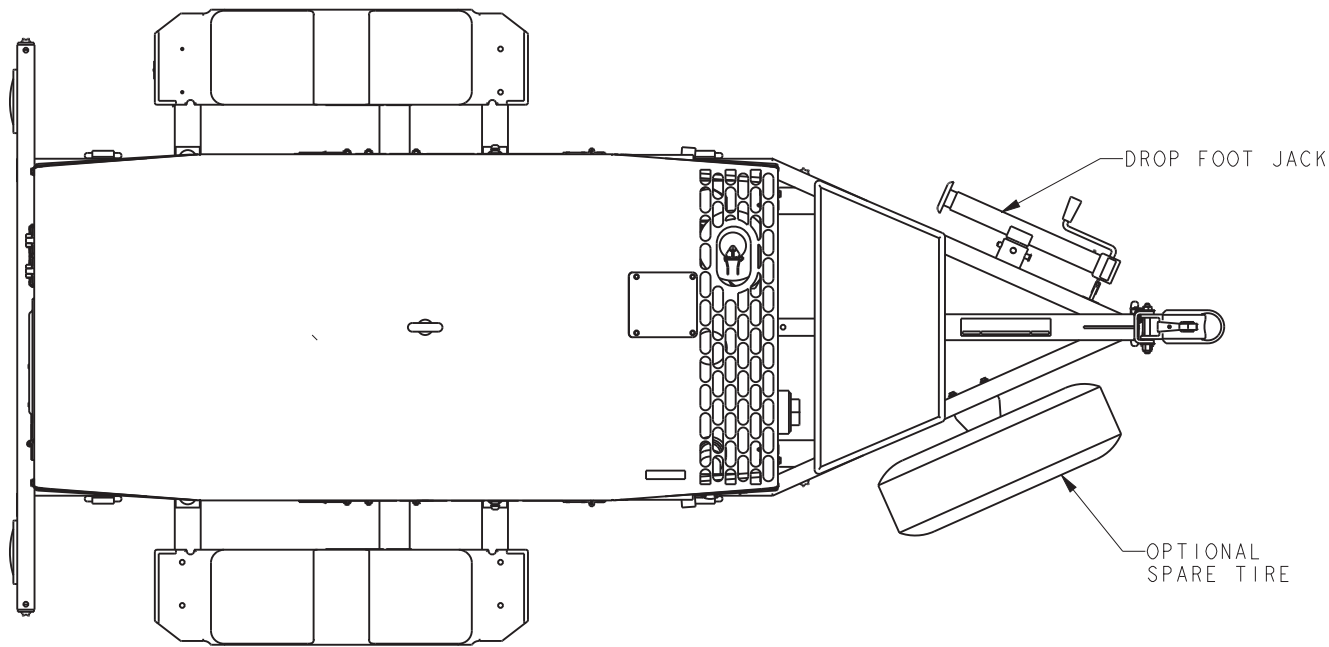

DIMENSIONS IN [ ] ARE IMPERIAL EQUIVALENTS  
WET WEIGHT INCLUDES ENGINE FLUIDS, EXCLUDING FUEL WEIGHT.  
WEIGHTS LISTED DO NOT INCLUDE OPTIONAL TOOL BOX AND SPARE TIRE KITS.

REV	DATE	ON COMPOSITE DWGS. SEE PART NO. FOR REVISION LEVEL	BY	DO NOT SCALE. REFERENCE THE MODEL FOR ALL UNSPECIFIED DIMENSIONS	
-	30SEP2019	NEW DRAWING [CT198480]	TKK	UNLESS OTHERWISE SPECIFIED: ALL DIMENSIONS IN MILLIMETERS GENERAL TOLERANCES: X.XX ± 0.25 SURFACE FINISH X.X ± 1.0 X ± 1.5 ANGLES ± 0°30' MAX. THIRD ANGLE PROJECTION	
A	12OCT2020	VIEWS UPDATED; (A-3) 3569.8 [140.54] WAS 3576.1 [140.79]; (B-5) 2030.9 [79.96] WAS 2087.2 [82.71]; (D-6) DRY & WET WEIGHT VALUES UPDATED; (A-7) 1866 [73.5] WAS 1867 [73.5]; (A-1) LUNETTE EYE 76.2 [3.00] WAS PINTLE HITCH 82.6 [3.25] I.D.; (D-8) CG X & CG Y VALUES UPDATED [CT207348]	PAR		
				APPROVALS	DATE
				DRAWN	TKK 30SEP2019
				CHECKED	GFR 30SEP2019
				APPROVED	AJW 30SEP2019
				SCALE	0.09   CAD NO.   SHEET 1 of 4
				TITLE <b>KOHLER</b> KOHLER, WISCONSIN 53044 THIS DRAWING IN DESIGN AND DETAIL IS KOHLER CO. PROPERTY AND MUST NOT BE USED EXCEPT IN CONNECTION WITH KOHLER CO. WORK. ALL RIGHTS OF DESIGN OR INVENTION ARE RESERVED. <b>DIMENSION PRINT, 35/45 REOZT4</b>	
				DWG NO. <b>ADV-9173</b>	

CENTER OF GRAVITY DIMENSIONS			WEIGHT DRY KG [LBS]	WEIGHT WET KG [LBS]
MODEL	CG X	CG Y		
35 REOZT4	1118 [44.0]	610 [24.0]	1374 [3030]	1397 [3080]
45 REOZT4	1105 [43.5]	610 [24.0]	1420 [3130]	1442 [3180]

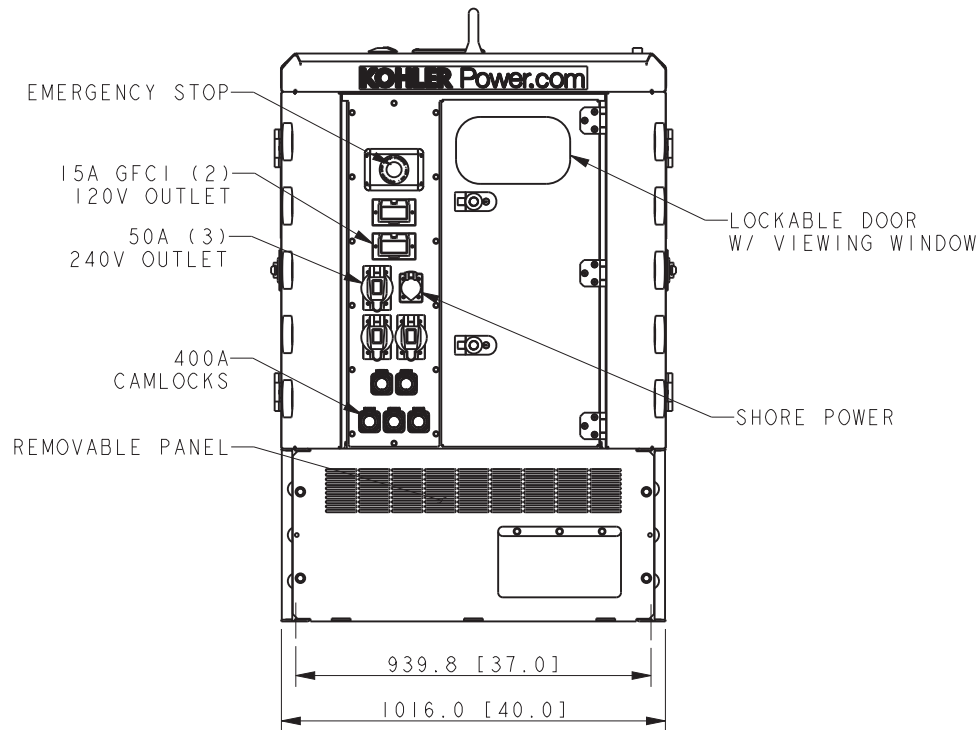

293 LITER [77 GAL.]  
FUEL TANK

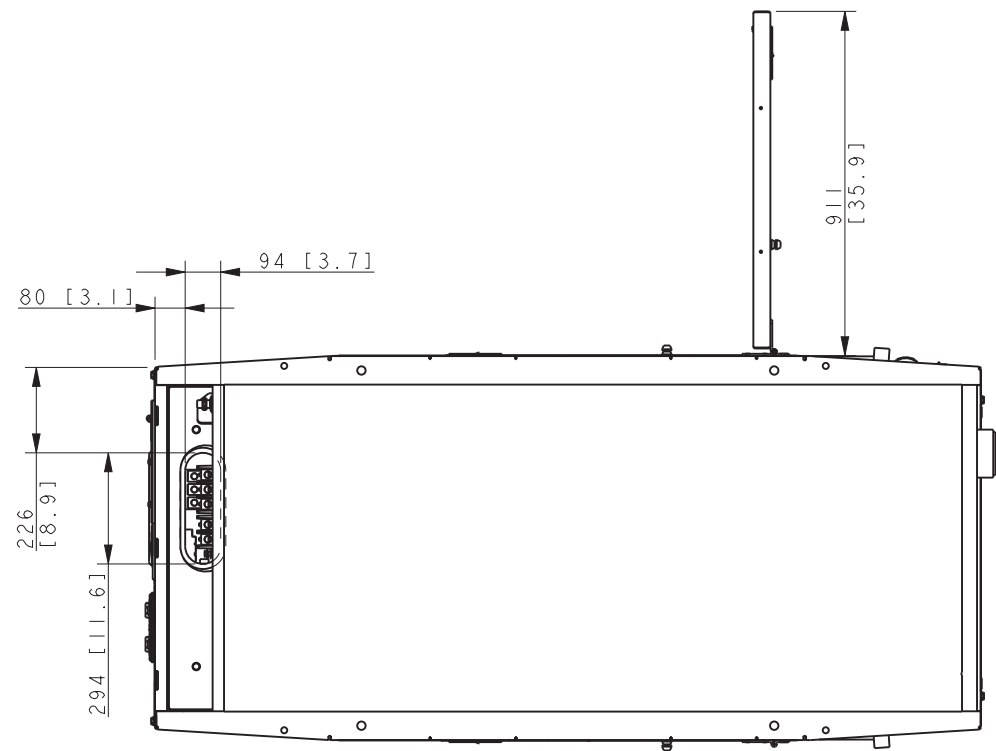
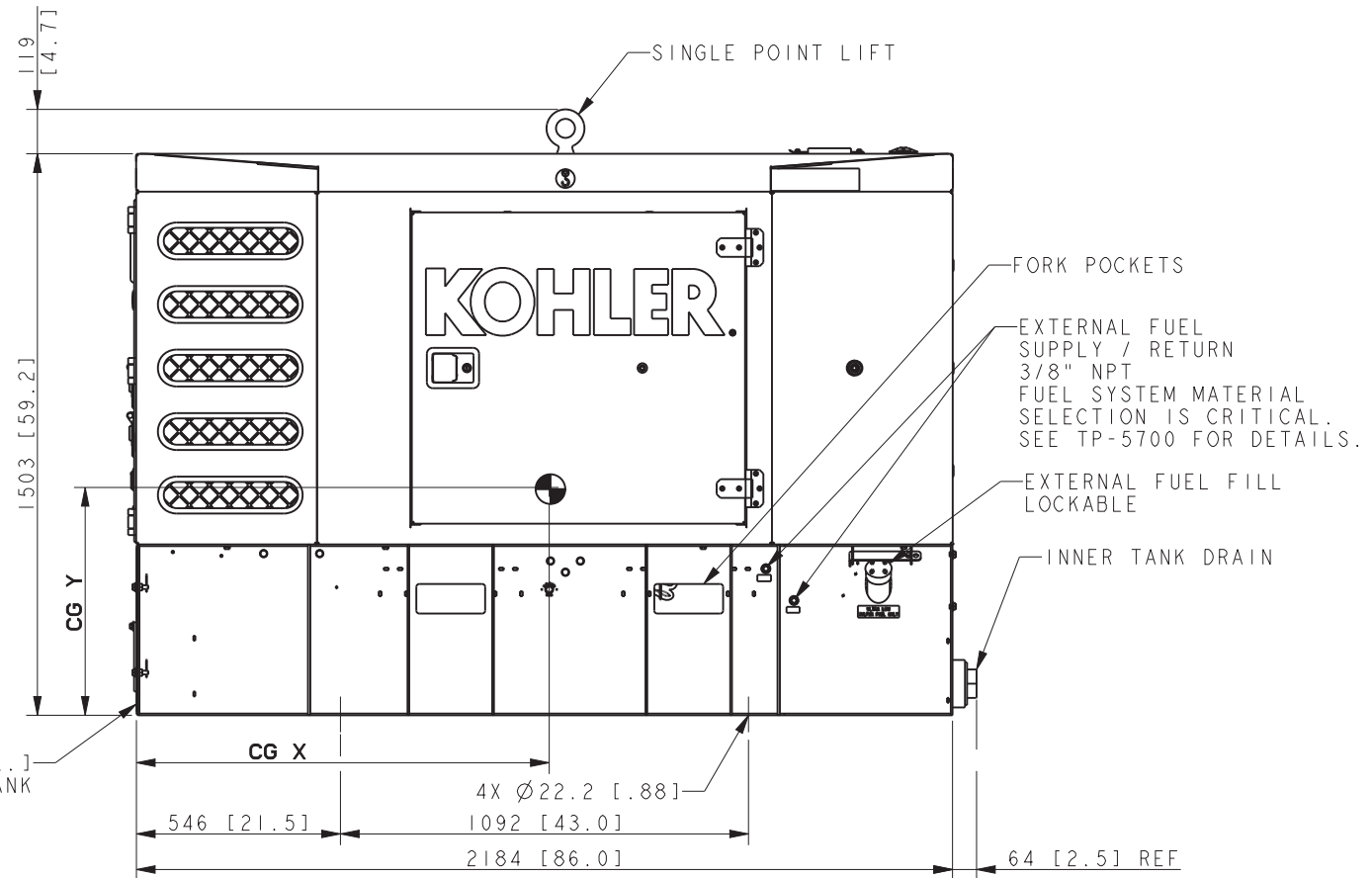

STANDARD TOWABLE  
35/45 REOZT4

REV	DATE	ON COMPOSITE DWGS. SEE PART NO. FOR REVISION LEVEL	BY	DO NOT SCALE. REFERENCE THE MODEL FOR ALL UNSPECIFIED DIMENSIONS
-	30SEP2019	NEW DRAWING [CT198480]	TKK	UNLESS OTHERWISE SPECIFIED: ALL DIMENSIONS IN MILLIMETERS GENERAL TOLERANCES: XX ± 0.25 X ± 0.5 X ± 1.0 ANGLES ± 0°30' MAX. SURFACE FINISH MAX.
A	12OCT2020	SEE SHEET 1 [CT207348]	PAR	
				<b>KOHLER</b> KOHLER, WISCONSIN 53044 THIS DRAWING IN DESIGN AND DETAIL IS KOHLER CO. PROPERTY AND MUST NOT BE USED EXCEPT IN CONNECTION WITH KOHLER CO. WORK. ALL RIGHTS OF DESIGN OR INVENTION ARE RESERVED.
				TITLE <b>DIMENSION PRINT, 35/45 REOZT4</b>
				APPROVALS      DATE DRAWN      TKK      30SEP2019 CHECKED      GFR      30SEP2019 APPROVED      AJW      30SEP2019
				SCALE 0.10      CAD NO.      SHEET 2 of 4 DWG NO. <b>ADV-9173</b> <b>D</b>

CENTER OF GRAVITY DIMENSIONS			WEIGHT DRY KG [LBS]	WEIGHT WET KG [LBS]
MODEL	CG X	CG Y		
35 REOZT4	1422 [55.97]	610 [24.0]	1438 [3170]	1461 [3220]
45 REOZT4	1422 [55.97]	610 [24.0]	1483 [3270]	1506 [3320]

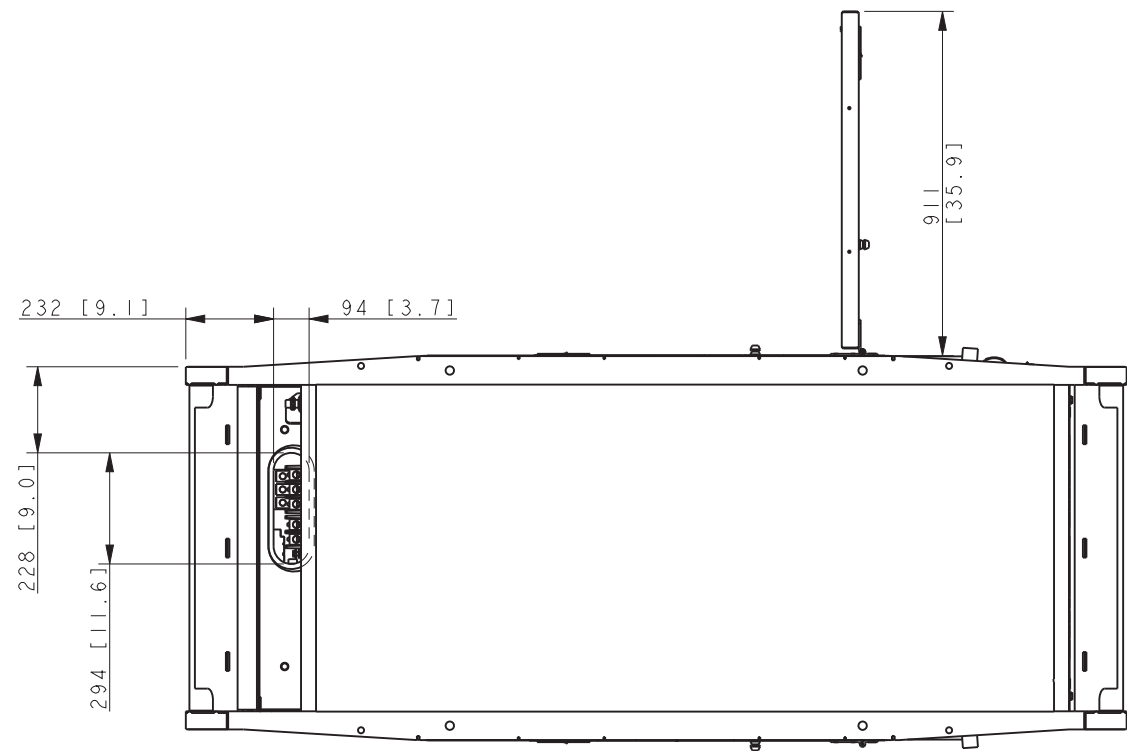
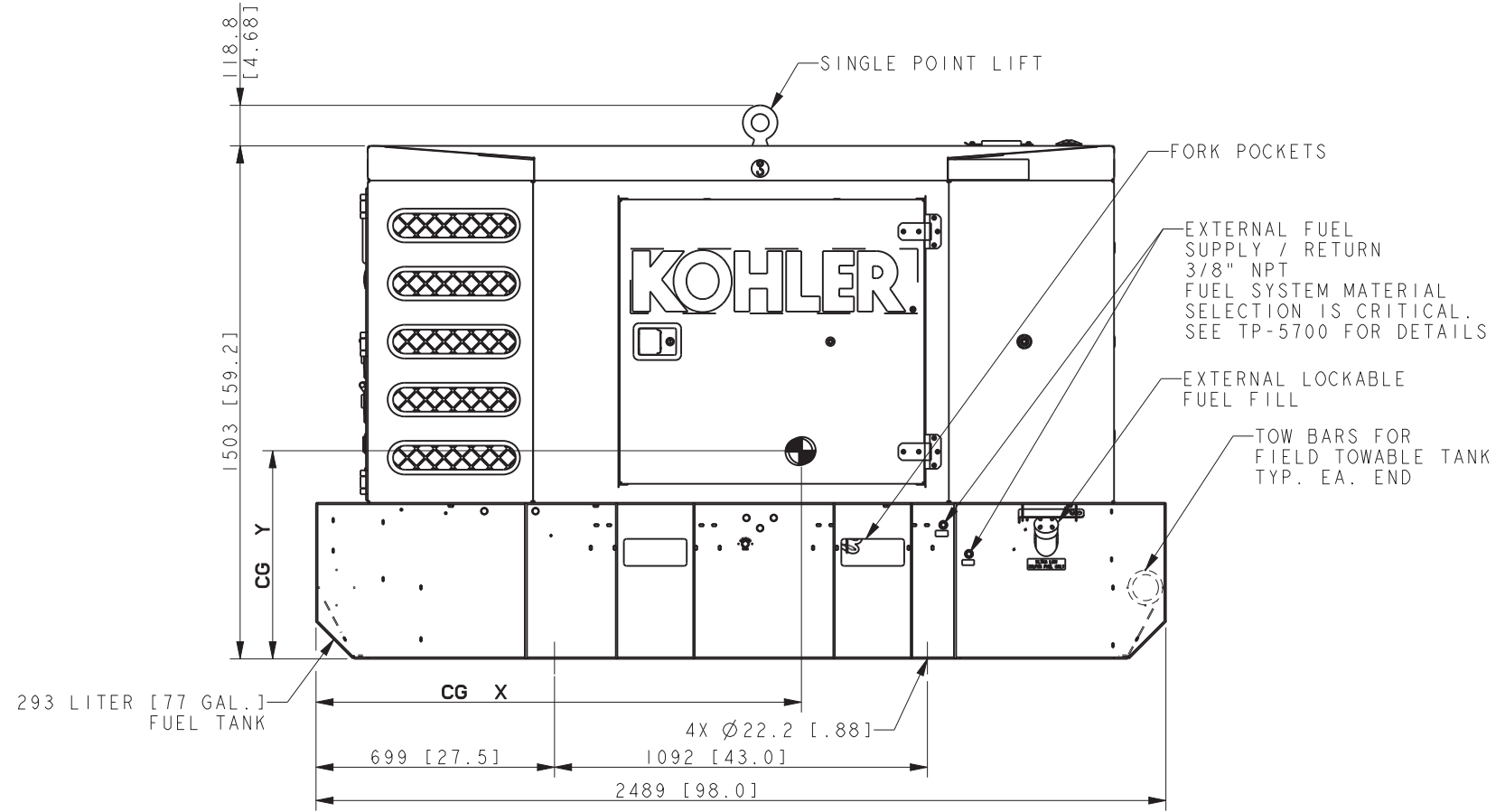
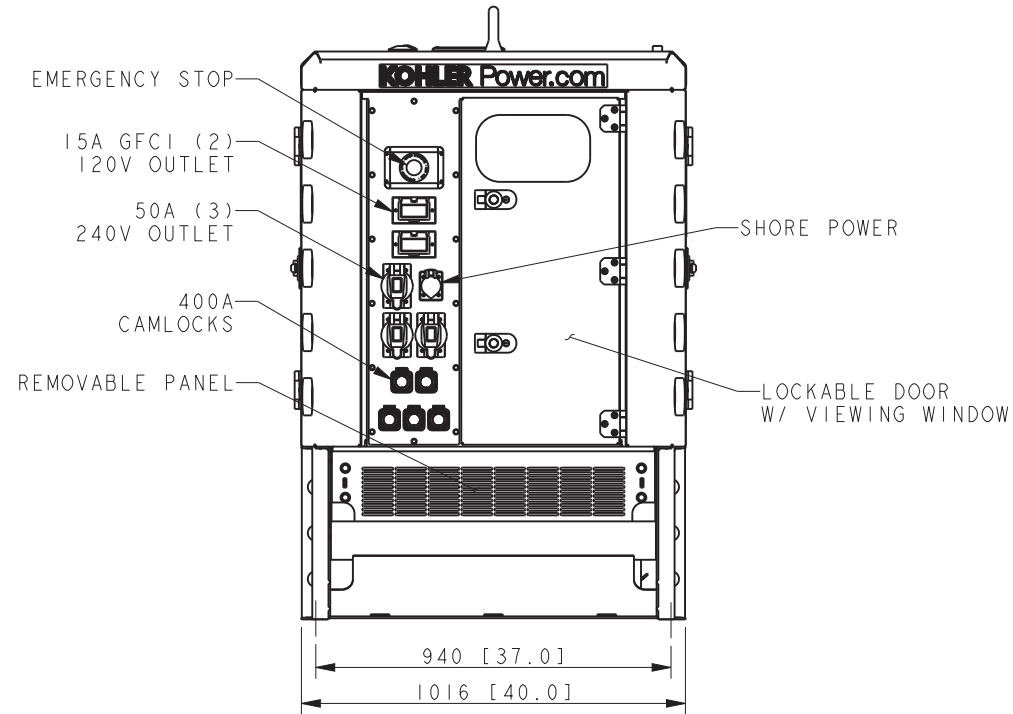

FIELD TOWABLE  
35/45 REOZT4

REV	DATE	ON COMPOSITE DWGS, SEE PART NO. FOR REVISION LEVEL	BY	DO NOT SCALE. REFERENCE THE MODEL FOR ALL UNSPECIFIED DIMENSIONS								
-	30SEP2019	NEW DRAWING [CT198480]	TKK	UNLESS OTHERWISE SPECIFIED: ALL DIMENSIONS IN MILLIMETERS GENERAL TOLERANCES: XX ± 0.25 X ± 1.0 SURFACE FINISH X ± 1.5 ANGLES ± 0°30' MAX. THIRD ANGLE PROJECTION								
A	12OCT2020	SEE SHEET 1 [CT207348]	PAR									
				<table border="1"> <tr> <th>APPROVALS</th> <th>DATE</th> </tr> <tr> <td>TKK</td> <td>30SEP2019</td> </tr> <tr> <td>GFR</td> <td>30SEP2019</td> </tr> <tr> <td>AJW</td> <td>30SEP2019</td> </tr> </table>	APPROVALS	DATE	TKK	30SEP2019	GFR	30SEP2019	AJW	30SEP2019
APPROVALS	DATE											
TKK	30SEP2019											
GFR	30SEP2019											
AJW	30SEP2019											
				<table border="1"> <tr> <td colspan="2">TITLE</td> </tr> <tr> <td colspan="2">DIMENSION PRINT, 35/45 REOZT4</td> </tr> <tr> <td>SCALE 0.10</td> <td>CAD NO.</td> </tr> <tr> <td>DWG NO. ADV-9173</td> <td>SHEET 3 of 4</td> </tr> </table>	TITLE		DIMENSION PRINT, 35/45 REOZT4		SCALE 0.10	CAD NO.	DWG NO. ADV-9173	SHEET 3 of 4
TITLE												
DIMENSION PRINT, 35/45 REOZT4												
SCALE 0.10	CAD NO.											
DWG NO. ADV-9173	SHEET 3 of 4											

**KOHLER.**  
KOHLER, WISCONSIN 53044  
THIS DRAWING IN DESIGN AND DETAIL IS KOHLER  
CO. PROPERTY AND MUST NOT BE USED EXCEPT IN  
CONNECTION WITH KOHLER CO. WORK. ALL RIGHTS  
OF DESIGN OR INVENTION ARE RESERVED.

CENTER OF GRAVITY DIMENSIONS			WEIGHT DRY KG [LBS]	WEIGHT WET KG [LBS]
MODEL	CG X	CG Y		
35 REOZT4	1104 [43.5]	590 [23.2]	975 [2150]	998 [2200]
45 REOZT4	1086 [42.8]	582 [22.9]	1021 [2250]	1043 [2300]

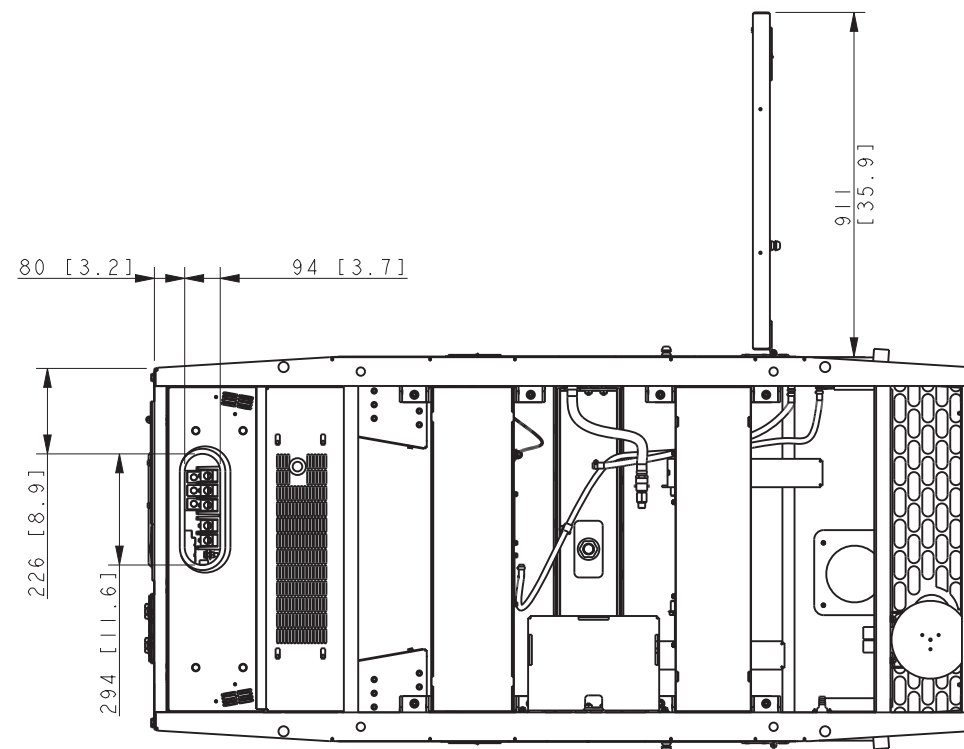
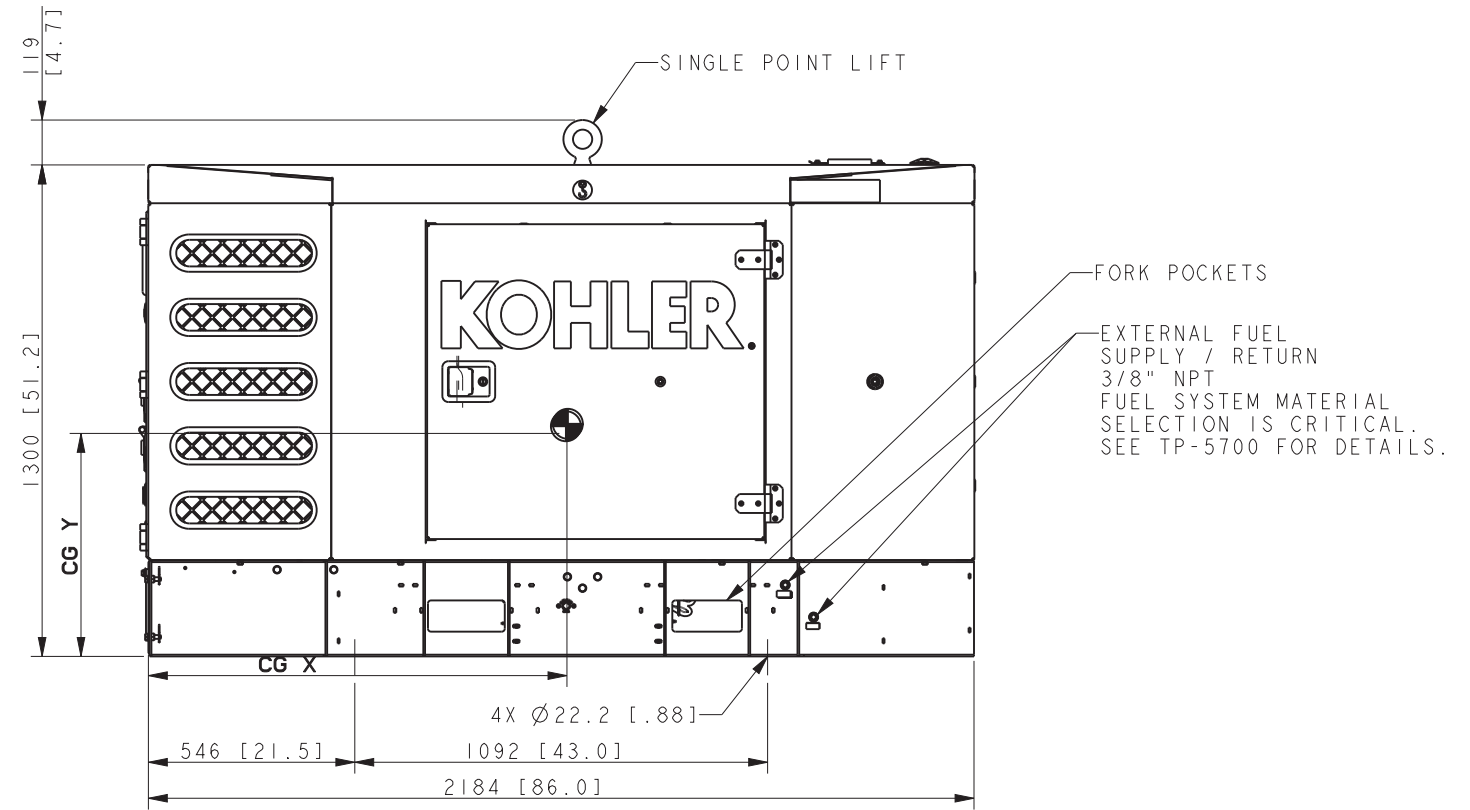
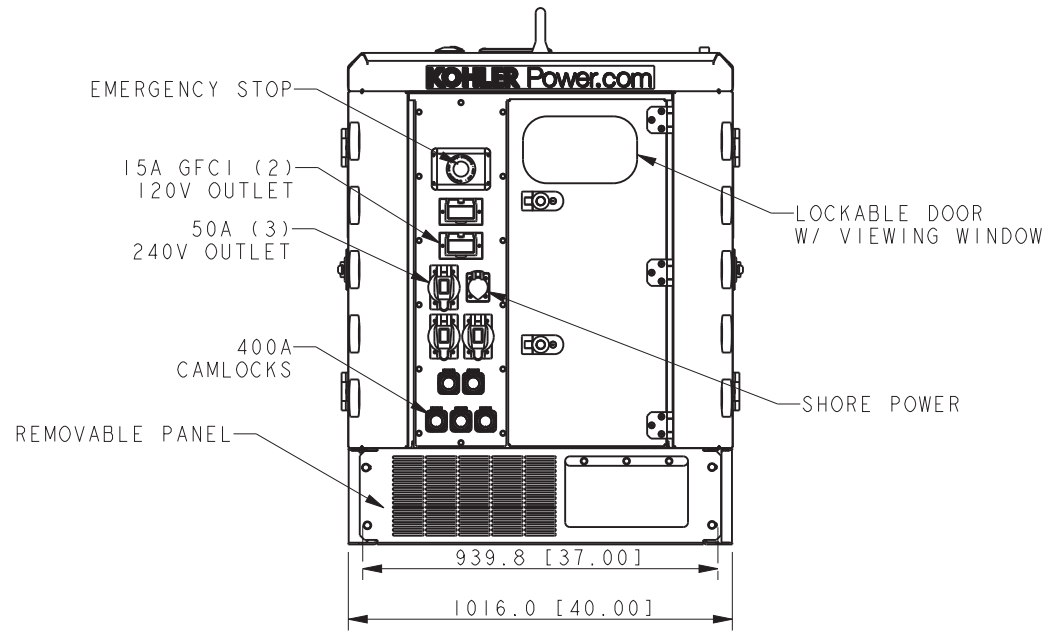

SKID ONLY  
35/45 REOZT4

REV	DATE	ON COMPOSITE DWGS. SEE PART NO. FOR REVISION LEVEL	BY	DO NOT SCALE. REFERENCE THE MODEL FOR ALL UNSPECIFIED DIMENSIONS
-	30SEP2019	NEW DRAWING [CT198480]	TKK	UNLESS OTHERWISE SPECIFIED: ALL DIMENSIONS IN MILLIMETERS GENERAL TOLERANCES: X.XX ± 0.25 X.X ± 1.0 SURFACE FINISH X ± 1.5 ANGLES ± 0°30' MAX. THIRD ANGLE PROJECTION
A	12OCT2020	SEE SHEET 1 [CT207348]	PAR	
				<b>KOHLER.</b> KOHLER, WISCONSIN 53044 THIS DRAWING IN DESIGN AND DETAIL IS KOHLER CO. PROPERTY AND MUST NOT BE USED EXCEPT IN CONNECTION WITH KOHLER CO. WORK. ALL RIGHTS OF DESIGN OR INVENTION ARE RESERVED. TITLE <b>DIMENSION PRINT, 35/45 REOZT4</b> SCALE 0.10 CAD NO. SHEET 4 of 4 DWG NO. <b>ADV-9173</b>
APPROVALS		DATE		
DRAWN		TKK 30SEP2019		
CHECKED		GFR 30SEP2019		
APPROVED		AJW 30SEP2019		